

A Message from
ILLINOIS ATTORNEY GENERAL
KWAME RAOUL



As Attorney General, it is my job to ensure that all Illinois residents, including people with disabilities, receive equal protection under the law. I am committed to working on behalf of people with disabilities to provide them with complete accessibility.

My office's Disability Rights Bureau employs a full-time staff that strives to make schools, the workplace and all public facilities open and available to everyone.

Questions and complaints about accessible parking represent one of the largest categories of inquiries to the Bureau. I hope that this brochure provides you with a clear understanding of the accessible parking laws.

If you have a question, see an improperly marked accessible parking space or find a facility without any accessible parking spaces, please contact the Disability Rights Bureau.

Kwame Raoul
Attorney General



KWAME RAOUL
ILLINOIS ATTORNEY GENERAL

If you see an improperly marked accessible parking space, or facilities with no such spaces, you can contact the Disability Rights Bureau with your complaint. Complaints can also be filed online at <https://www.illinoisattorneygeneral.gov/rights-of-the-people/disability-rights/>

DISABILITY RIGHTS BUREAU

CHICAGO

115 South LaSalle Street
Chicago, Illinois 60603
1-312-814-5684

SPRINGFIELD

500 South Second Street
Springfield, Illinois 62701
1-217-524-2660

Individuals with hearing or speech disabilities can reach us by using the 7-1-1 relay service.

For more information about Illinois parking laws visit <https://www2.illinois.gov/cdb/announcements/2018/Documents/Register%20Page.pdf>.

www.IllinoisAttorneyGeneral.gov

ACCESSIBLE PARKING

FOR PEOPLE WITH DISABILITIES

A GUIDE TO YOUR RIGHTS UNDER THE LAW



KWAME RAOUL
ILLINOIS ATTORNEY GENERAL

Accessible Parking: Know the Rules

Any facility offering parking for employees or visitors must provide accessible parking for people with disabilities. An accessible parking space consists of a vehicle space and a diagonally striped access aisle. The entire space must be kept clear of obstructions—including ice, snow, shopping cart corrals, trash cans, seasonal garden displays and bicycle racks—at all times.



Illustration of a legal angled accessible parking space.

SIZE AND MARKINGS

Each accessible parking space, except on-street spaces, shall be 16 feet wide, including either an eight-foot or five-foot wide diagonally striped access aisle. The access aisle may be located on either side of the vehicle space except for angled parking spaces, which shall have the access aisle located on the passenger side of the vehicle space. Access aisles shall be marked with diagonal striping so as to discourage parking in them. Two parking spaces may share an access aisle except for angled parking spaces. High-quality yellow paint, manufactured especially for pavement striping, must be used.

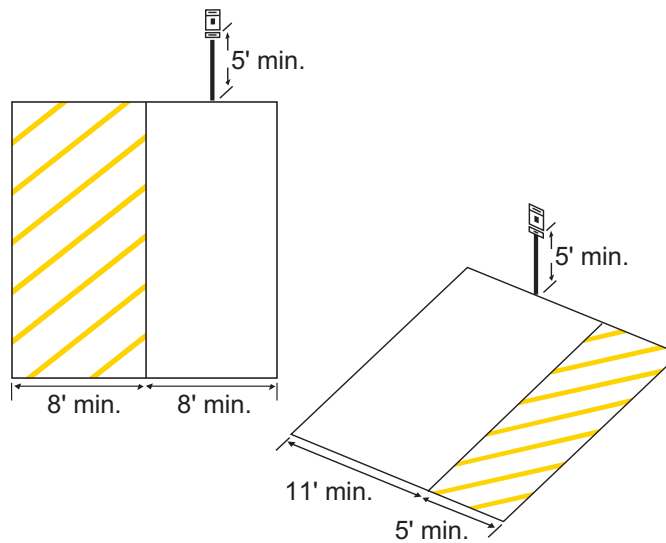

Illustration of two examples of legal accessible parking spaces.

LOCATION

Accessible parking must be placed on level pavement on the shortest accessible route to an accessible facility entrance. The accessible route, which may include a curb ramp or curb cut, must be installed as close as possible to the accessible entrance it serves. Additionally, a curb ramp must never be built so that it protrudes into or interferes with the diagonally striped access aisle of an accessible space.

SIGNS

A U.S. Department of Transportation R7-8 (Reserved Parking) and R7-1101 (\$250 Fine) sign must be permanently mounted in the center of the parking space. The signs must be vertically mounted on a post or wall at front center of the parking space, no more than 6 feet horizontally from the front of the parking space. At a minimum, the bottom of the R7-8 sign must be 5 feet from the pavement. Municipalities may impose a larger fine through the adoption of a local ordinance.

PROPER USE OF LICENSE PLATES/PLACARDS

Under Illinois law, disability license plates, disabled veterans plates and placards are not transferable. The authorized holder must be present and must enter or exit the vehicle at the time the parking privileges are being used. Unauthorized use can result in a \$600 fine, driver's license suspension and suspension or revocation of the plate or placard by the Illinois Secretary of State.

SPACE REQUIREMENTS

To comply with Illinois law, a minimum number of accessible parking spaces must be provided:

Total Off-Street Parking Spaces Provided	Number of Accessible Parking Spaces Required
1 to 25	1
26 to 50	2
51 to 75	3
76 to 100	4
101 to 150	5
151 to 200	6
201 to 300	7
301 to 400	8
401 to 500	9
501 to 1,000	2% of total
over 1,000	20 plus 1 for each 100 over 1,000
Hospital Outpatient Facilities providing regular or continuing medical treatment without an overnight stay	10% of total
Rehabilitation and Outpatient Physical Therapy Facilities specializing in treating conditions that affect mobility	20% of total